

OUTRIDER CF™



Ultra Compact DVR Provides Broadcast Quality Video and Audio for Portable Applications

STANDARD FEATURES

- Scalable Motion JPEG compression
- Analog Composite & Y/C Inputs & Outputs
- Flash Drive Interface
- Time-Lapse Recording
- PC Viewable Files or Secure Video Files
- Time/Date Stamp & Character Display
- Loop Record
- Low 3 Watt Power Consumption
- 6 GPI Switch Inputs
- 5 GPI LED Outputs
- RS-232 Control
- NTSC or PAL
- 2 audio channels
- USB 2.0 Port

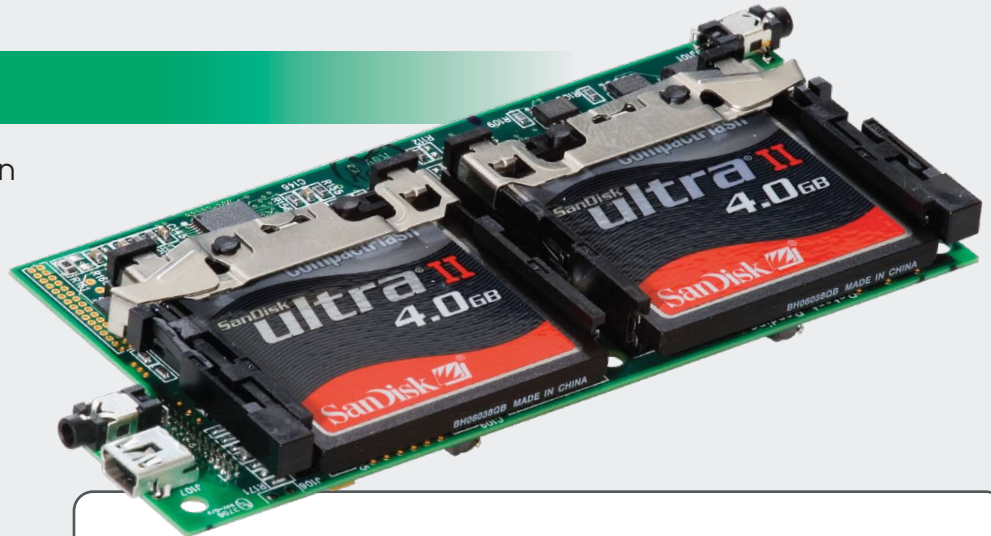

The ultra-compact Outrider CF digital video recorder, measures only 5.1”L x 2.2”W x 0.6”D. With its broadcast level image quality and low 3 watt power consumption, it is ideal for portable, high resolution recording applications including: surveillance, law enforcement, emergency first responders and portable broadcasters.

Designed with the same leading-edge, digital video technology that established Fast Forward Video’s reputation as the standard in the broadcast industry, the Outrider CF is loaded with enhanced features and delivers broadcast quality video.

It features video capture and playback at true 60 fields per second, the Outrider CF offers resolution greater than 550 lines at 4:1 compression, user-selectable compression ratios from 4:1 to 20:1 and recording times averaging between 4 to 20 minutes per GB. The GPI control options include record, seek, or scan forward/backward; single-frame forward/reverse; delete clips; and play/pause.

Outrider CF’s standard features include: time/date stamp and character display; time-lapse recording; NTSC/PAL compatibility; composite and Y/C inputs and outputs; pre-event record; external triggers; and loop record. Easily transfer recorded video with the on-board USB 2.0 port. Video can be recorded as PC-viewable QuickTime™ files or secure video files.

APPLICATIONS

- In Vehicle
- On Body
- Remote / Portable
- Airborne
- OEM

MARKETS

- Military / Intelligence
- Law Enforcement
- Broadcast/Film
- Medical
- Surveillance

FV: 03/20/09OCF

Fast Forward Video

1151 Duryea Avenue, Irvine, California 92614

Ph. 949.852.8404

A DVR Technology Company

VIDEO INPUT	
Analog Input:	Composite and S-Video (Y/C)
Levels:	1.0Vp-p, 75 ohms
Standards:	525/60 (NTSC) or 625/50 (PAL)
VIDEO OUTPUT	
Analog Output:	Composite and S-Video (Y/C)
Horizontal Resolution:	550 TV lines (at 5:1 compression)
Levels:	1.0Vp-p, 75 ohms
Standards:	525/60 (NTSC) or 625/50 (PAL)
Connections:	Multi-pin for component
VIDEO INPUT DECODER	
Format:	Digital 4:2:2 YCrCb 60 fields per second NTSC 50 fields per second PAL
Digital Color Space:	YUV
Sampling:	13.5 MHz
Pixel Resolution:	720 x 486 pixels (525/60) 720 x 576 pixels (625/50)
S/N Ratio:	50 dB
Bandwidth:	7 MHz (-3 dB)
Differential Gain:	2%
Differential Phase:	2 deg.
ADC Differential Linearity:	+/- 0.7 LSB
ADC Integral Linearity:	+/- 1.0 LSB
VIDEO OUTPUT ENCODER	
Digital Color Space:	Digital 4:2:2 YCrCb
Analog Bandwidth:	Y: 6.75 MHz C: 1.3 MHz
Composite:	4.5 MHz (NTSC) 5.0 MHz (PAL)
DAC Resolution:	10 bits x 3
S/N Ratio:	60 dB
VIDEO COMPRESSION	
Codec:	Zoran
Method:	JPEG (Joint Photographic Experts Group)
Compression Ratio:	Variable from 4:1 to 20:1
COMPACT FLASH	
Protocol:	ATAPI DMA Mode 3
Maximum Data Rate:	16.6 MB/sec
Maximum Compact Flash:	2 slots (8GB)
Supported CF Card:	SanDisk Ultra II - SDCFH-4096 or Extreme III - SDCFX3-4096
Record Time:	4 to 20 minutes per GB

MICROPROCESSOR	
Type:	Intel 80386EX
Clock Speed:	40 MHz
Local ROM/EPROM:	1 MB Flash EEPROM 1 MB 0 wait state
Local SRAM:	
COMMUNICATIONS INTERFACE	
RS-232 Interface:	Conforms to Sony Remote (9 pin) protocol-38400 baud, 8 data bits, odd parity, 1 stop bit 2.0
USB Port:	
AUDIO SPECIFICATIONS	
Resolution:	16 bits
Channels:	2 in, 2 out
Dynamic Range:	80 dB
Total Harmonic Distortion:	0.22%, -73 dB
Intermodulation Distortion:	90 dB
Crosstalk:	-80 dB
Interchannel Gain Mismatch:	+/- 0.5 dB
Input Voltage:	1 VRMS nominal, 3V p-p max
Input Impedance:	20k ohms
Full Scale Output Voltage:	0.707 VRMS, 2.0V p-p
Output Impedance:	600 ohms
Sampling Rate, FS:	48 KHz
MICROPHONE INPUT	
Input Signal Level (0 dB):	1.0 VRMS
Signal-to-Noise Ratio 0 dB gain:	80 dB
Dynamic Range:	
-60 dB full-scale input:	80 dB
Total Harmonic Distortion:	
-1 dB input, 0 dB gain:	-60 dB
Input Resistance:	14 K Ohms
STEREO HEADPHONE OUTPUT	
Maximum Output Power:	40 mW into 16 ohms
Signal-to-Noise Ratio:	90 dB
Total Harmonic Distortion:	1.0%
SOFTWARE	
	FFV DVR Master
GENERAL	
Size:	4.9"L x 2.2"W x 0.7"D (124.5mmL x 55.9mmW x 15.24mmD) 1.0 oz (28.35 grams)
Weight:	
Power Consumption:	3 watts not including storage device(s)
Input Voltage:	Compact Flash: +3.5 to 9.5 Volts
Operating Temperature:	0c to 50c
Humidity:	90% relative humidity with no visible condensation
WARRANTY:	1 year

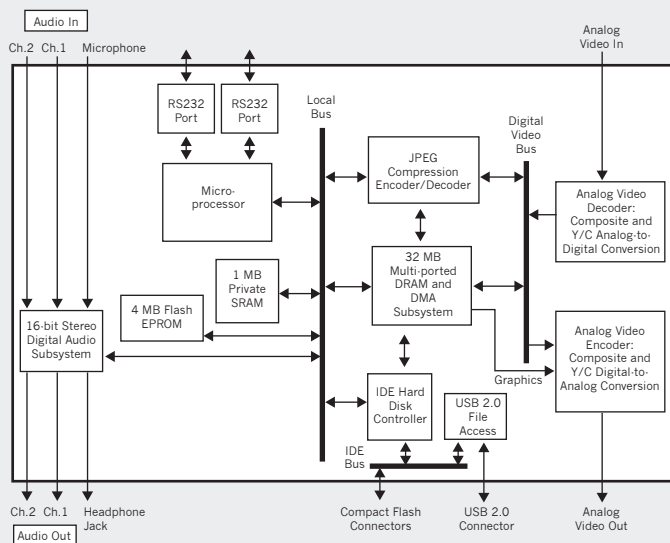

Fast Forward Video

1151 Duryea Avenue
Irvine, California 92614

www.ffv.com
sales@ffv.com

Ph. 949.852.8404
Fx. 949.852.1226